



ALL-STAR® PRODUCTS

TurboBlower

eCATALOG

TURBOBLOWER eCATALOG

This new edition of the All-Star eCatalog introduces several new features to aid in your effort to locate the product that best meets your application requirements. Additionally, the selection procedure has been streamlined to simplify your search.

For example, all of the model numbers in the Index and in the Composite curve are "hot linked" to the model number page. This eliminates your having to scroll through dozen of pages to get to the page you need.

Secondly, complete engineering information is provided, so you can evaluate your product selection more carefully. This new information includes temperature rise within the blower and also motor temperature rise. Output kW is included to help in determining the efficiency of your selection.

WEBSITE CONTENT

The All-Star website will be updated shortly with the information contained in the Standard and the Engineered blower eCatalog. In addition, the website will provide AutoCad drawings for the full line of blowers.



TURBO BLOWER

Ratings to 1725 SCFM and 15.7 "H2O



HIGH FLOW - LOW PRESSURE

Higher Flow, Lower Noise and High Efficiency due to special impeller design

Long Service life - aluminum construction for excellent heat dissipation

Low Vibration - Computerized balancing of components

High Performance - Electric motor designed and manufactured in house to optimize blower performance. Shaft seals thoroughly seal the motor from intake air circulation.

CNC manufacturing assures high-accuracy tolerances for peak performance.

MODEL	kW	HP	Voltage	FL Amps	Pressure Max "H2O	Flow Max SCFM	Outlet Dia	Sound dB	Weight Kgs	Weight Lbs
TB05-3*	0.4	1/2	230/460	2.0/1.0	5.9	315	3"	70	18	40
TB1-3*	.75	1	230/460	3.2/1.6	10.4	675	4"	80	30	66
TB205-3**	1.9	2.5	230/460	6.2/3.1	12.6	800	4"	90	40	88
TB305-3	2.2	3.5	230/460	8.3/4.1	15	1400	5"	96	60	133
TB5-3	3.7	5	230/460	13.4/6.7	15.7	1725	5"	100	74	164

* Available in 1/60/50/115/230 volts ** Available in 1/60/50/230 volts

Common Applications

Woodworking Machinery
Incinerators
Drying Machinery
Burner Air Supply
Hot Air Balloons

Plastic Extruders
Textile Machinery
Printing Machinery
Cooling Machinery
Air Curtains



All-Star™ Products

Your source for all of your blower and vacuum pump requirements

Centrifugal Blowers to 50,000 SCFM

Turbine Blowers to 1590 CFM

Regenerative Blowers to 2500 SCFM to 11.5 psi

Rocking Piston Compressors & Vacuum Pumps

Rotary Vane Compressors & Vacuum Pumps

All-Star Products

2095 Exeter Rd Ste 80-3234 Memphis, TN 38138

<http://www.all-star-usa.com>

All-Star™, HB™ Series and Big Bertha Blowers™ are registered trademarks.



Turboblower Performance Curve

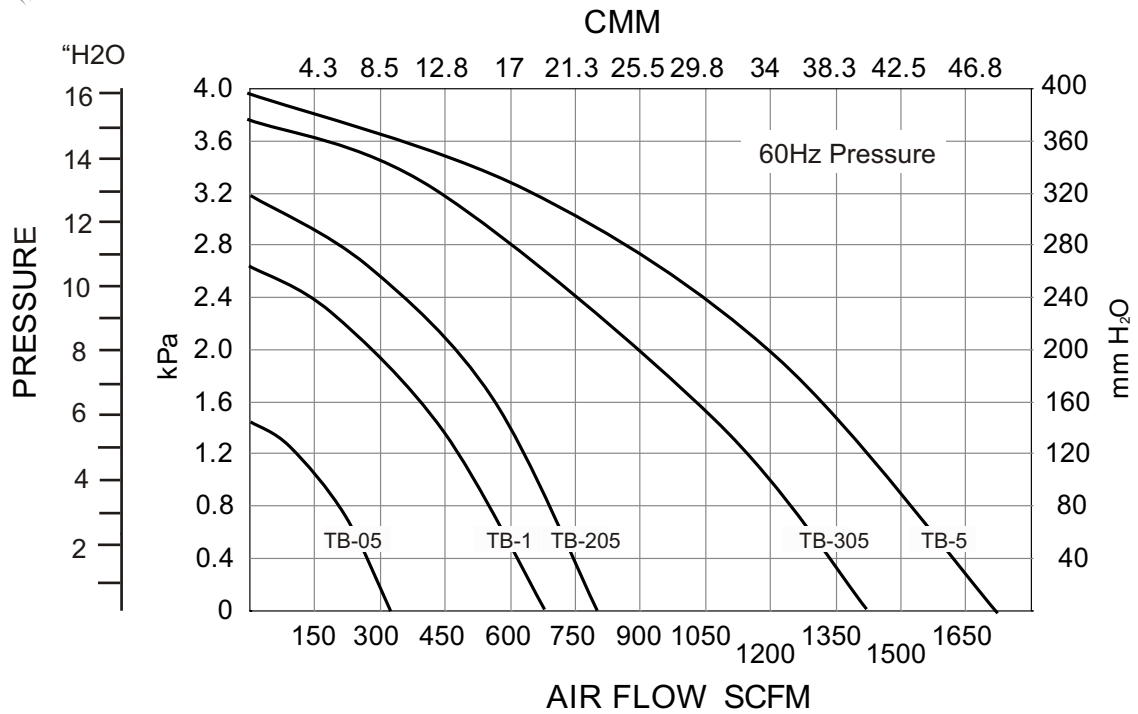

MODEL	A	B	C	D	E	F	G	H	K	L	M	N	R	T	U	W	Y
TB-05-3	5.3	5.3	4.6	8.26	7.28	7.28	2.76	7.99	14.76	13.98	15.55	4.5	.39	.47	3.93	3	1.96
TB1-3	5.3	6.5	4.92	9.92	7.48	9.05	2.63	9.64	17.71	14.45	17.71	6.02	.51	.59	4.92	4	2.16
TB205-3	5.5	6.5	6.10	10.35	7.48	9.64	3.26	10.52	19.29	17.13	19.49	6.14	.51	.59	4.92	4	2.76
TB305-3	5.5	7.67	7.28	11.02	9.05	11.02	3.94	11.93	21.25	19.49	21.65	6.49	.63	.59	7.08	5	3.35
TB5-3	13.8	9.45	7.87	13.78	16.33	11.22	4.52	12.80	24.60	21.26	25.39	3.97	.63	.78	7.08	5	2.56

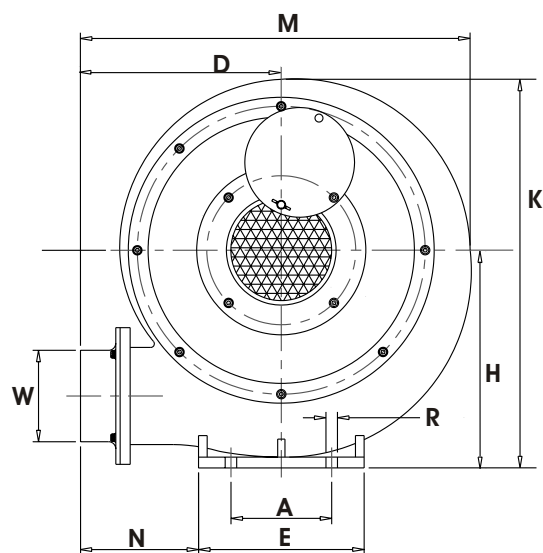
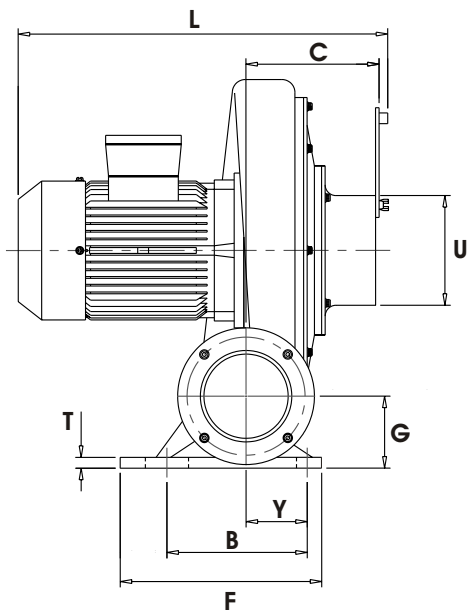

TURBOBLOWER
ePRODUCT CATALOG
INDEX

March, 2007

TB05-1
Dimension Page
Single Phase Performance Data Page

TB1-1
Dimension Page
Single Phase Performance Data Page

TB05-3
Dimension Page
Three Phase Performance Data Page

TB1-3
Dimension Page
Three Phase Performance Data Page

TB205-3
Dimension Page
Three Phase Performance Data Page

TB305-3
Dimension Page
Three Phase Performance Data Page

TB5-3
Dimension Page
Three Phase Performance Data Page

All-Star TurboBlower TB05 - Pressure - Single Phase

50Hz - - - - -

60Hz _____

The technical data is based on 1 bar (abs.) free atmosphere and 20°C with Inlet air density 1.2kg/m³, ±10 %variance.

March , 2007

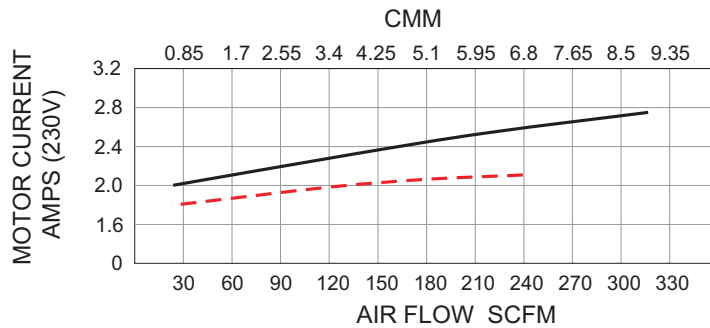
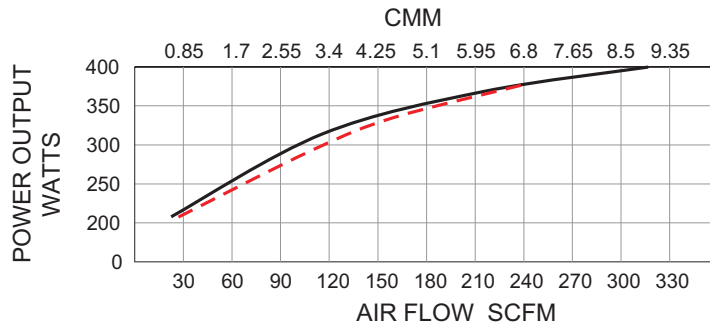
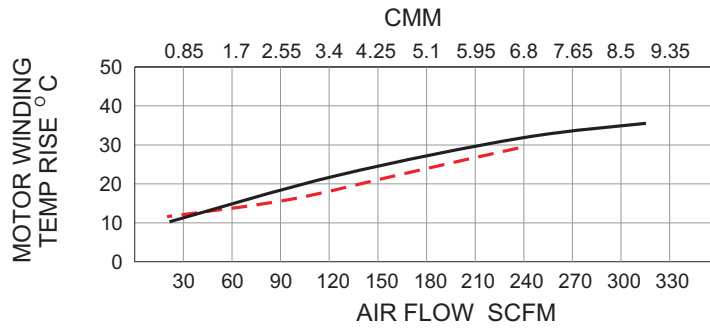
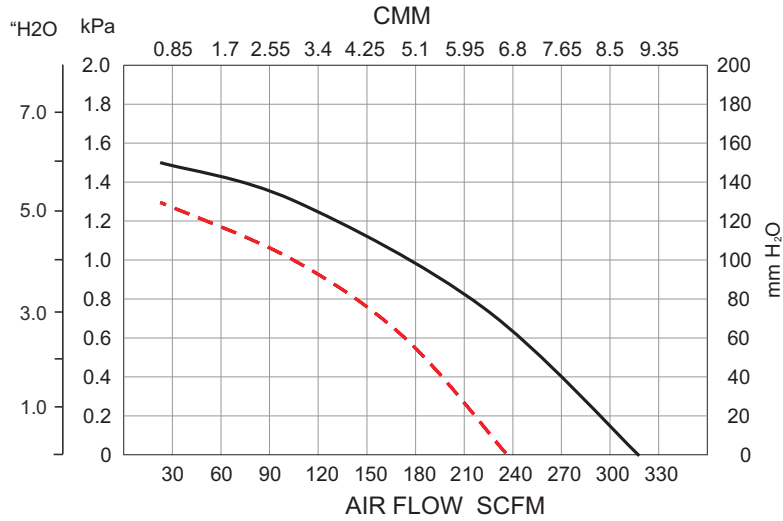

All-Star TurboBlower TB1 - Pressure - Single Phase

50Hz - - - - -

60Hz _____

The technical data is based on 1 bar (abs.) free atmosphere and 20°C with Inlet air density 1.2kg/m³, ±10 %variance.

March , 2007

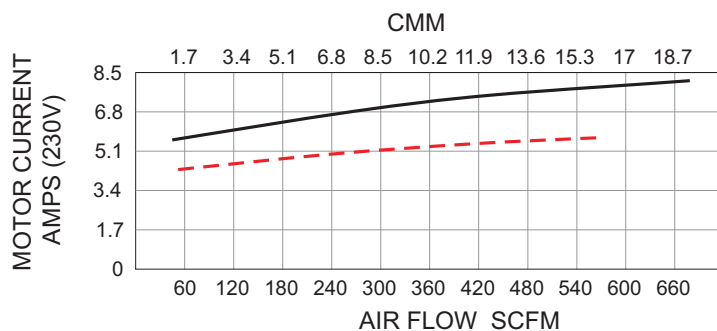
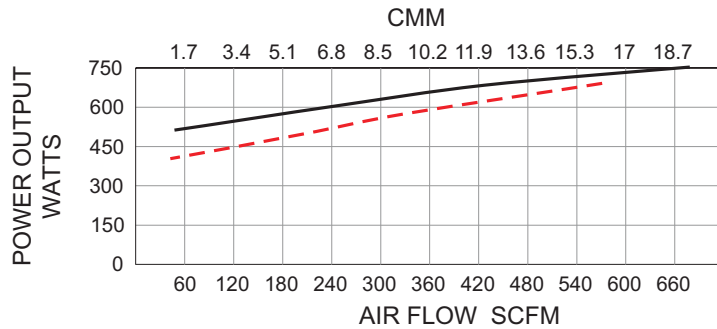
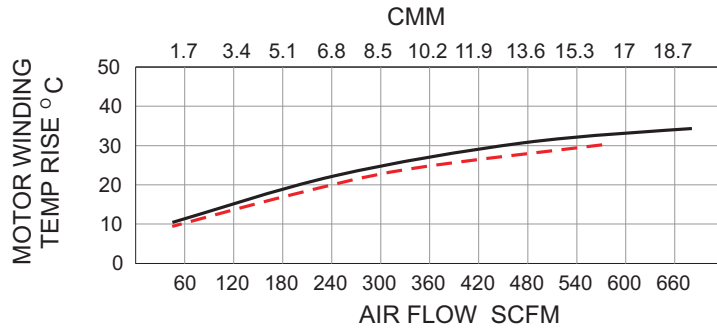
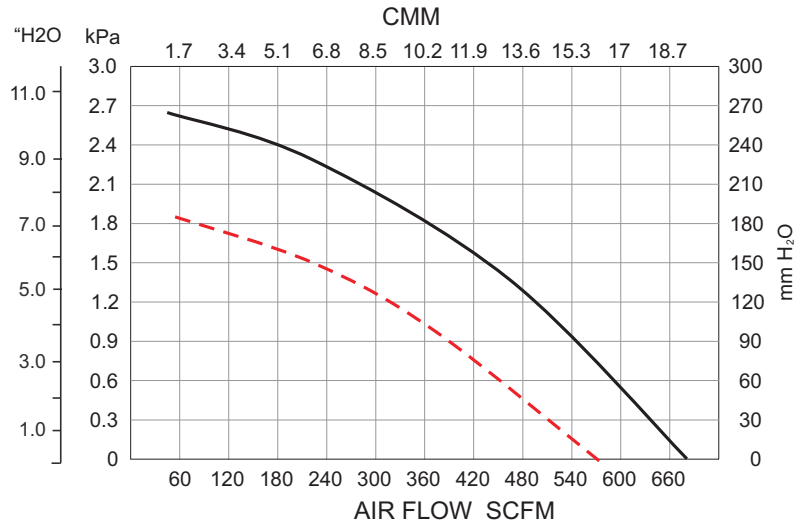

All-Star TurboBlower TB205 - Pressure - Three Phase

50Hz - - - - -

60Hz _____

The technical data is based on 1 bar (abs.) free atmosphere and 20°C with Inlet air density 1.2kg/m³, ±10 %variance.

March , 2007

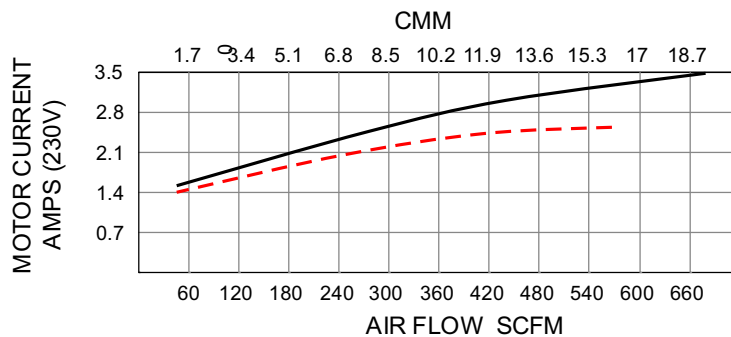
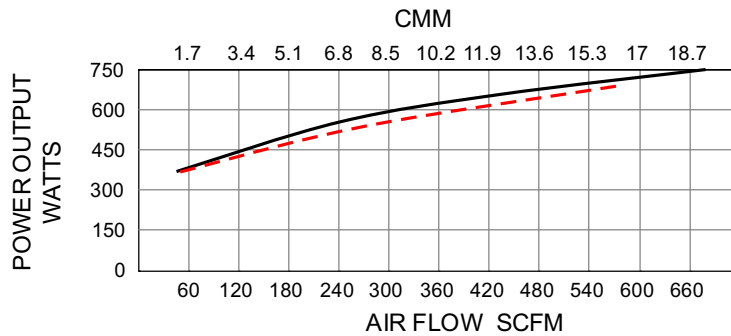
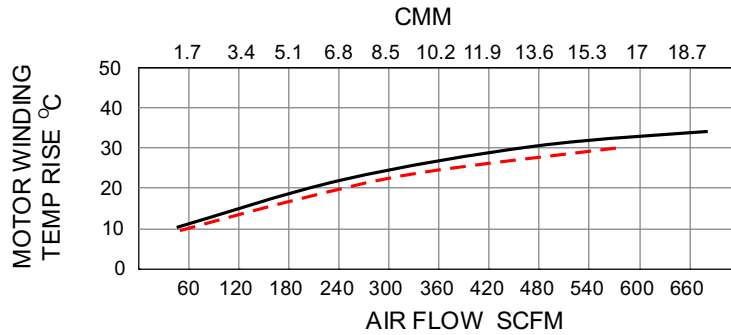
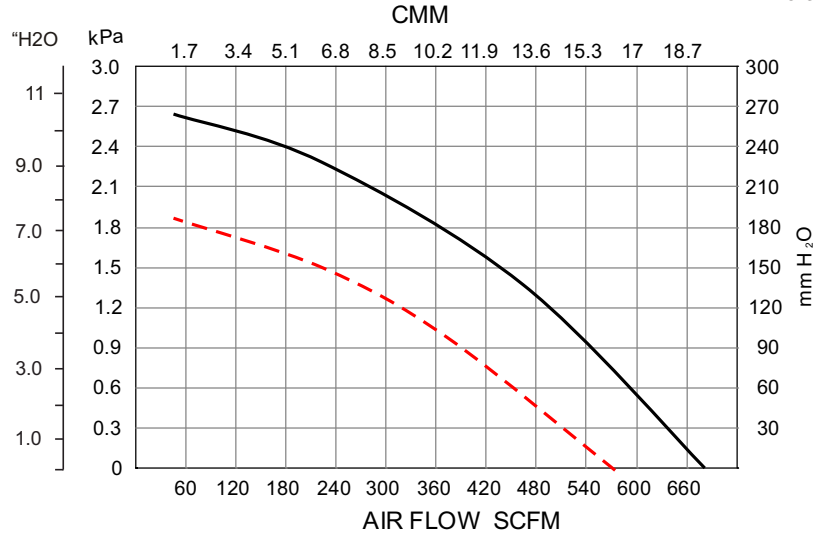

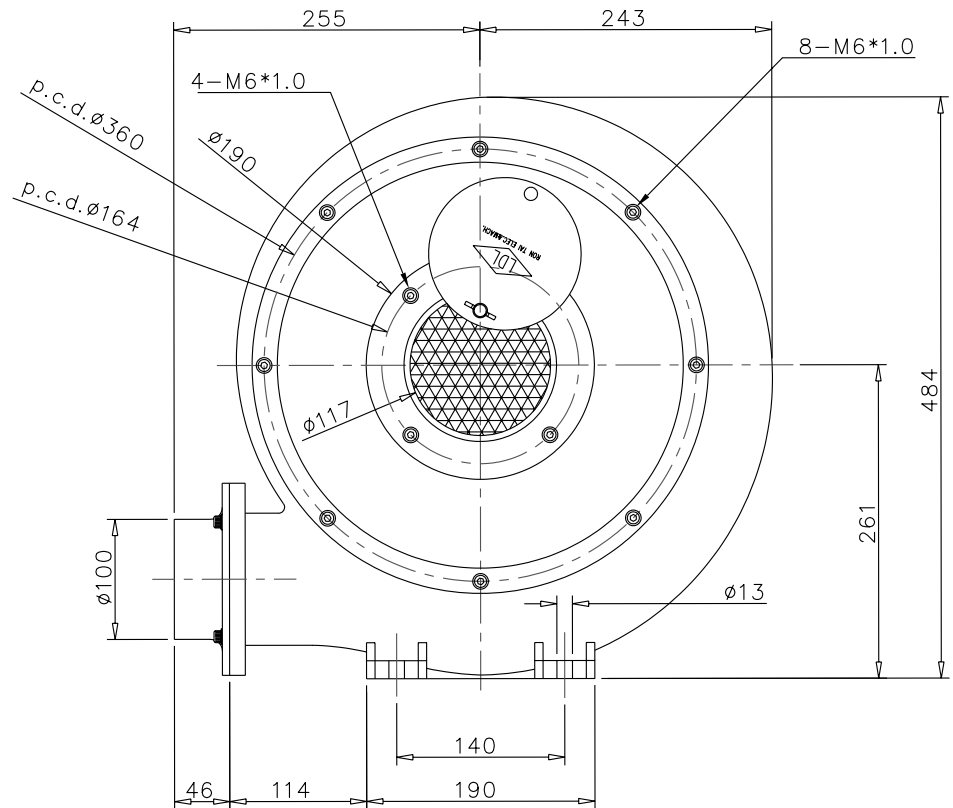
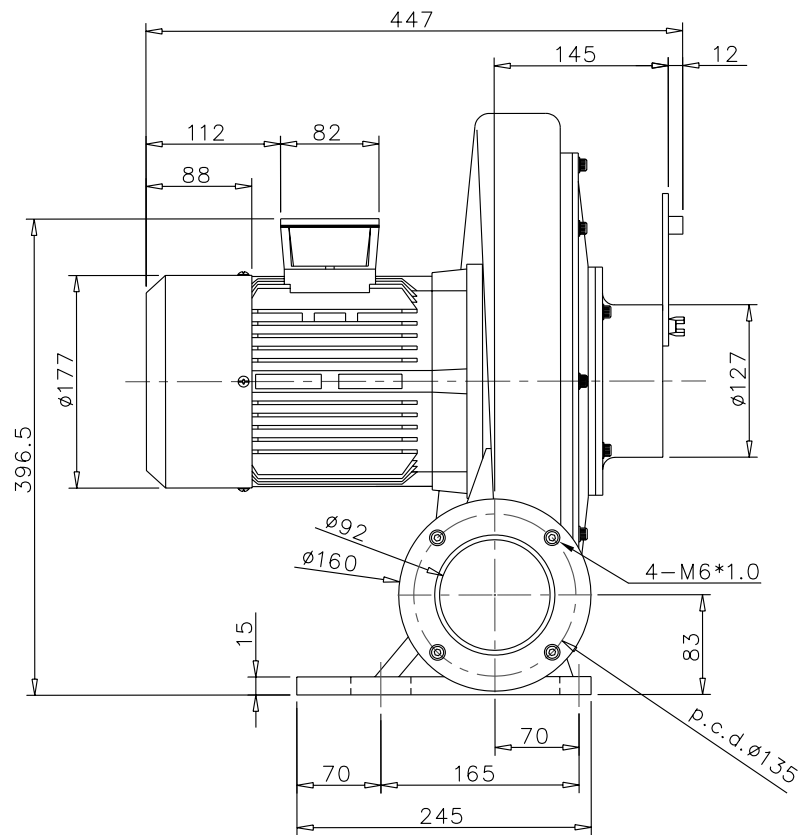

ALL-STAR PRODUCTS INC
 Cleveland Ohio Memphis Tennessee

TURBO BLOWER
 MODEL TB205

February 6, 2007

All-Star TurboBlower TB305 - Pressure - Three Phase

50Hz - - - - -

60Hz _____

The technical data is based on 1 bar (abs.) free atmosphere and 20°C with Inlet air density 1.2kg/m³, ±10 %variance.

March , 2007

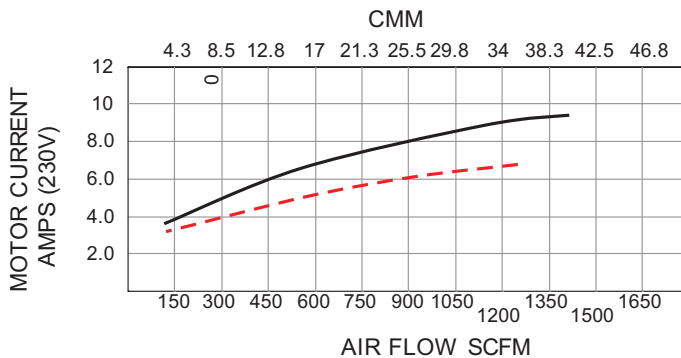
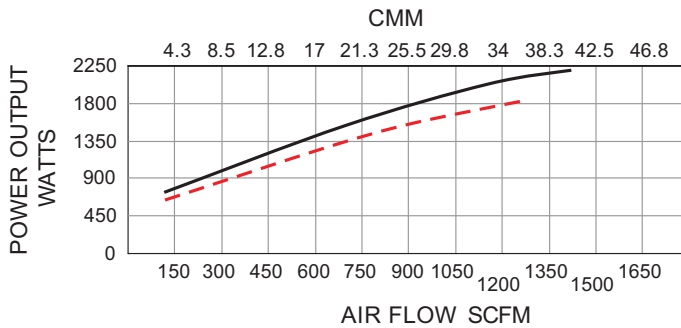
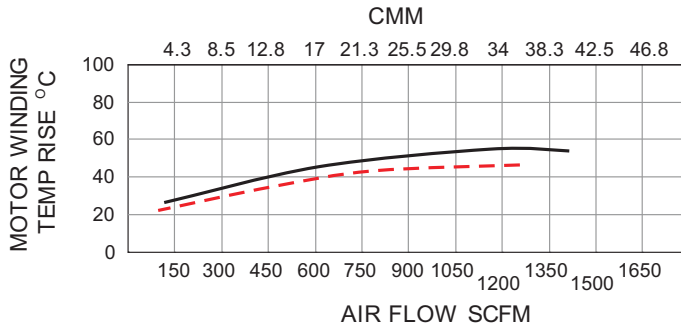
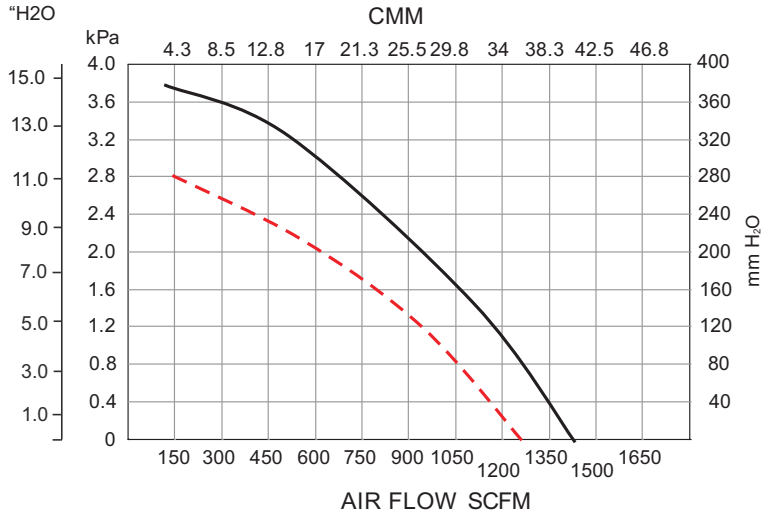

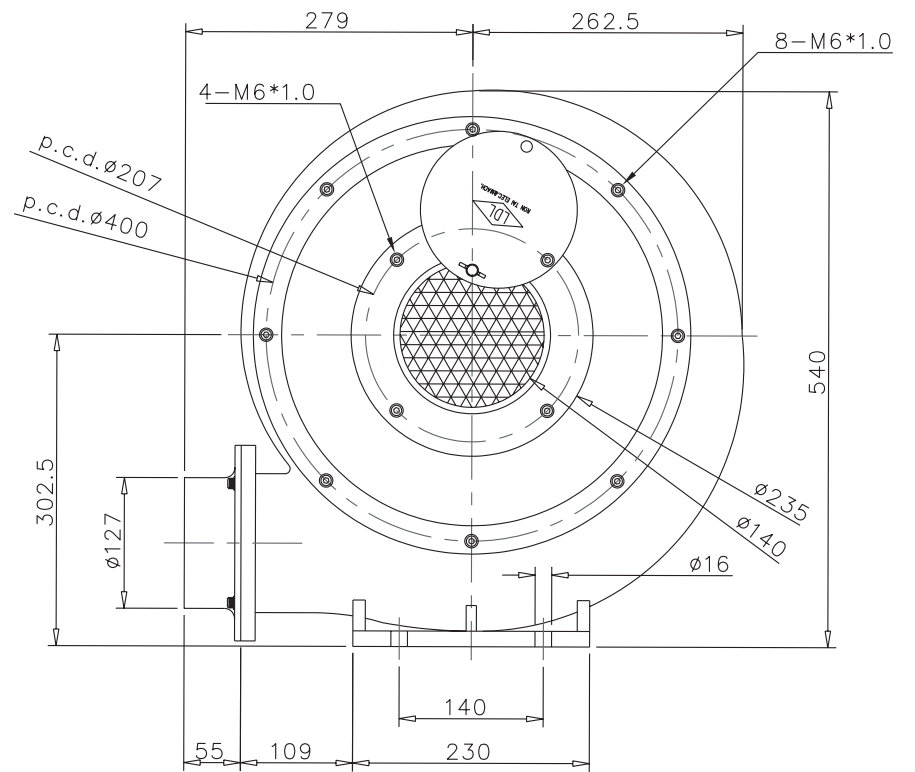
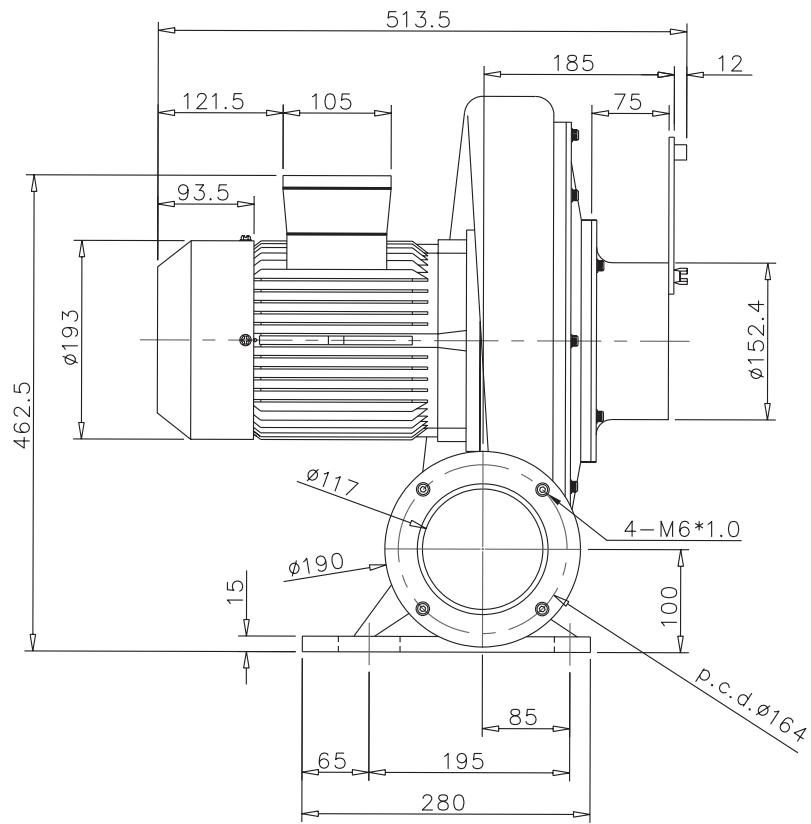

ALL-STAR PRODUCTS INC
 Cleveland Ohio Memphis Tennessee

TURBO BLOWER
 MODEL TB305

March 5, 2007

All-Star TurboBlower TB5 - Pressure - Three Phase

50Hz - - - - -

60Hz _____

The technical data is based on 1 bar (abs.) free atmosphere and 20°C with Inlet air density 1.2kg/m³, ±10 %variance.

March , 2007

